

FNAME: WS1P-TP-(1001-1004)

REVDATE: 0621

REVISIONS				
ZONE	REV	DESCRIPTION	DATE	AUTHOR
	L	UPDATED WWD BOARD REVISION	6/15/21	AO

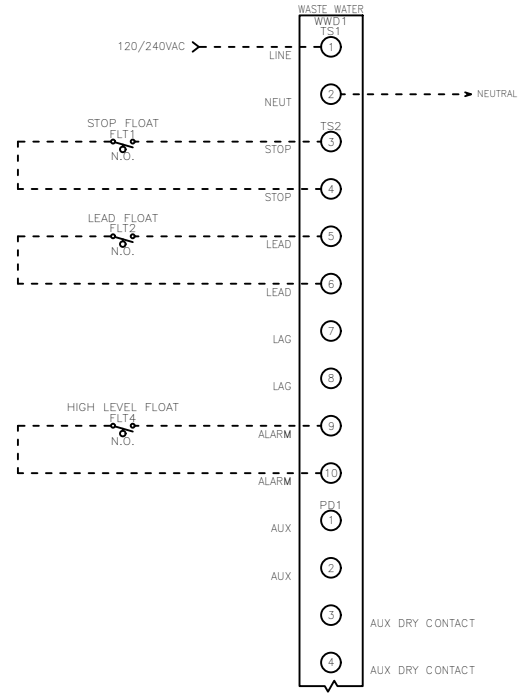
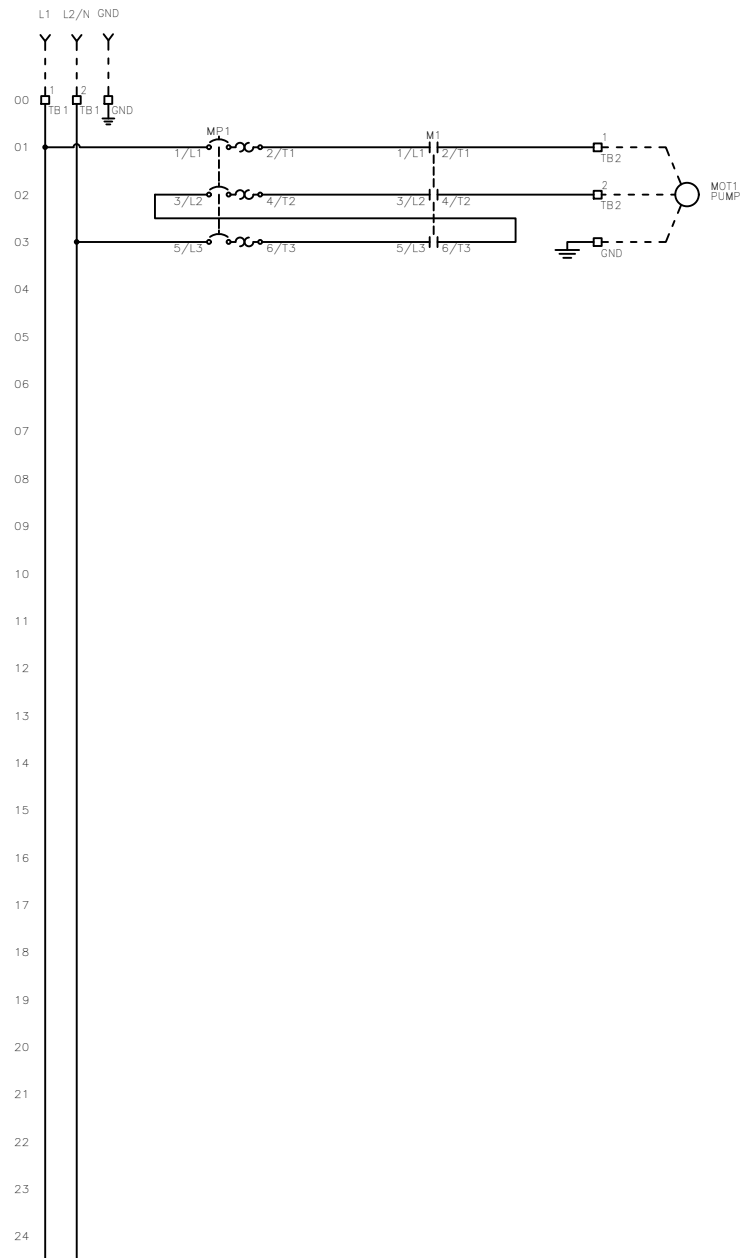

----- DASHED LINE INDICATES FIELD WIRING.

USE COPPER CONDUCTORS ONLY.

TEMPERATURE RATING OF CONDUCTORS IS TO BE:
 60°C (140°F) FOR UNDER 100A.
 75°C (167°F) FOR OVER 100A.

BRANCH CIRCUIT PROTECTION SHALL BE PROVIDED BY THE INSTALLER: MUST BE SIZED ACCORDING TO PUMP/MOTOR MANUFACTURING SPECIFICATIONS.

VERIFY CORRECT OPERATION OF CONTROL PANEL AFTER INSTALLATION IS COMPLETE.

FIELD WIRING TORQUE SPECS.	
TERMINAL BLOCK UT 2,5	5 IN-LB
TERMINAL BLOCK UT 4	7 IN-LB
TERMINAL BLOCK UT 6	15 IN-LB
TERMINAL BLOCK UT 10	15 IN-LB
TERMINAL BLOCK UT 16	25 IN-LB
TERMINAL BLOCK UT 35	30 IN-LB
TS1, TS2, J1, J2 & J3 PCB	9 IN-LB
TRANSFORMER H1F, H2F & H3F	15 IN-LB
TRANSFORMER H1, H2 & H3	10 IN-LB
DS1 VLS3P63-125 R2	45 IN-LB
DS1 LK4JU3CN 100A	36 IN-LB
DS1 LK4MU3N 200A	200 IN-LB

DRAWN BY: MM
 DATE: 10/25/14

APPROVED BY: KM
 DATE: 10/25/14

THIS DRAWING CONTAINS PROPRIETARY INFORMATION AND SHALL NOT BE USED OR DISCLOSED WITHOUT PRIOR WRITTEN AUTHORIZATION.



TITLE: WS1P-TP-(1001-1004) CONTROL SCHEMATIC			
SIZE: B	DWG NO.: 1523	PART NO.: WS1P-TP-(1001-1004)	REV: L
SCALE: NONE		SHEET: 1 OF 2	

FNAME: WS1P-TP-(1001-1004)

REVDATE: 0621

REVISIONS				
ZONE	REV	DESCRIPTION	DATE	AUTHOR
	L	UPDATED WWD BOARD REVISION	6/15/21	AO

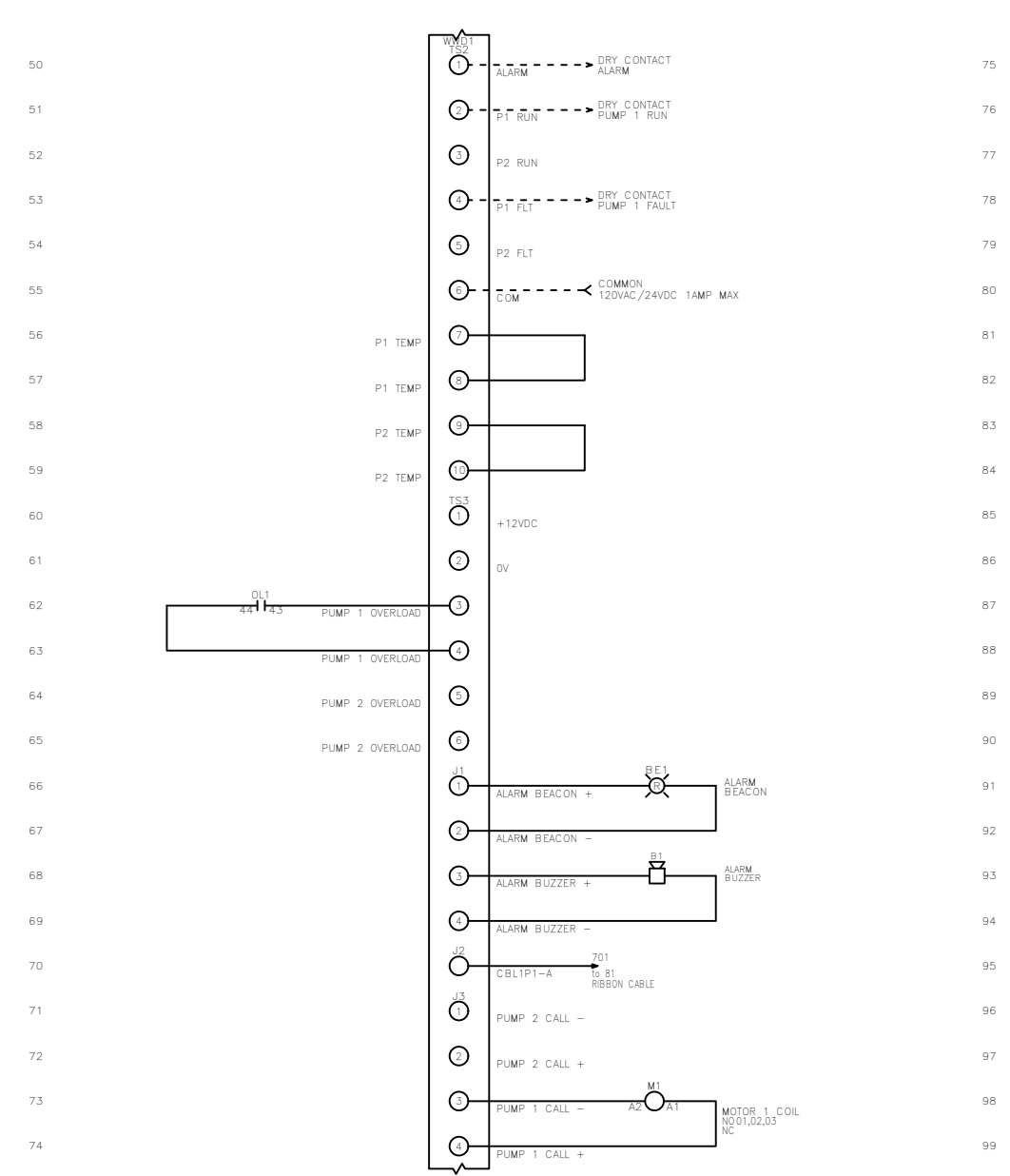

----- DASHED LINE INDICATES FIELD WIRING.

USE COPPER CONDUCTORS ONLY.

TEMPERATURE RATING OF CONDUCTORS IS TO BE:
 60°C (140°F) FOR UNDER 100A.
 75°C (167°F) FOR OVER 100A.

BRANCH CIRCUIT PROTECTION SHALL BE PROVIDED BY THE INSTALLER; MUST BE SIZED ACCORDING TO PUMP/MOTOR MANUFACTURING SPECIFICATIONS.

VERIFY CORRECT OPERATION OF CONTROL PANEL AFTER INSTALLATION IS COMPLETE.

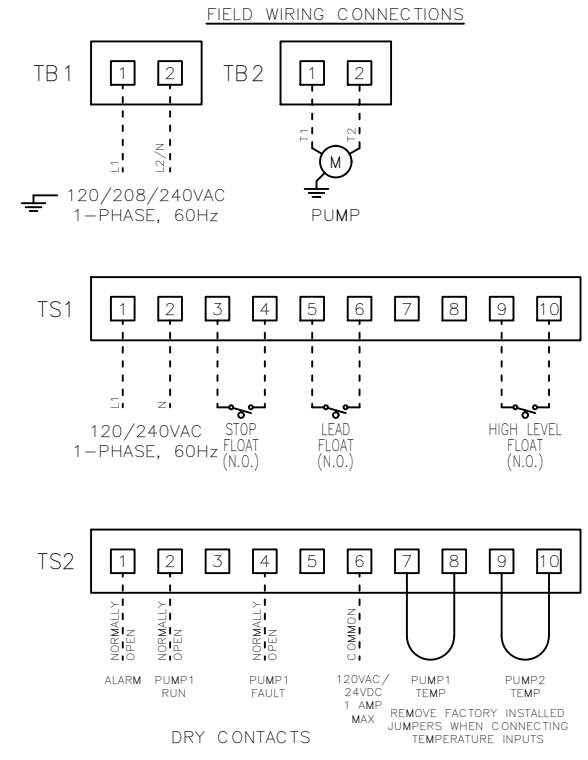
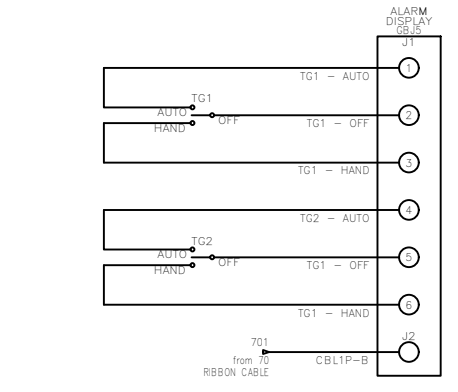

FIELD WIRING TORQUE SPECS.	
TERMINAL BLOCK UT 2,5	5 IN-LB
TERMINAL BLOCK UT 4	7 IN-LB
TERMINAL BLOCK UT 6	15 IN-LB
TERMINAL BLOCK UT 10	15 IN-LB
TERMINAL BLOCK UT 16	25 IN-LB
TERMINAL BLOCK UT 35	30 IN-LB
TS1, TS2, J1, J2 & J3 PCB	9 IN-LB
TRANSFORMER H1F, H2F & H3F	15 IN-LB
TRANSFORMER H1, H2 & H3	10 IN-LB
DS1 VLS3P63-125 R2	45 IN-LB
DS1 LK4JU3CN 100A	36 IN-LB
DS1 LK4MU3N 200A	200 IN-LB

DRAWN BY: MM DATE: 10/25/14

APPROVED BY: KM DATE: 10/25/14

THIS DRAWING CONTAINS PROPRIETARY INFORMATION AND SHALL NOT BE USED OR DISCLOSED WITHOUT PRIOR WRITTEN AUTHORIZATION.



TITLE: WS1P-TP-(1001-1004) CONTROL SCHEMATIC			
SIZE: B	DWG NO.: 1523	PART NO.: WS1P-TP-(1001-1004)	REV: L
SCALE: NONE	SHEET: 2 OF 2		